

<b>DW#</b>	<b>A1-QC02f</b>	<b>PQ2/SQ2 - RWH - QCC2</b>	<b>Revision Record</b>
------------	-----------------	-----------------------------	------------------------

Date	Dim./Spec.	Old	New

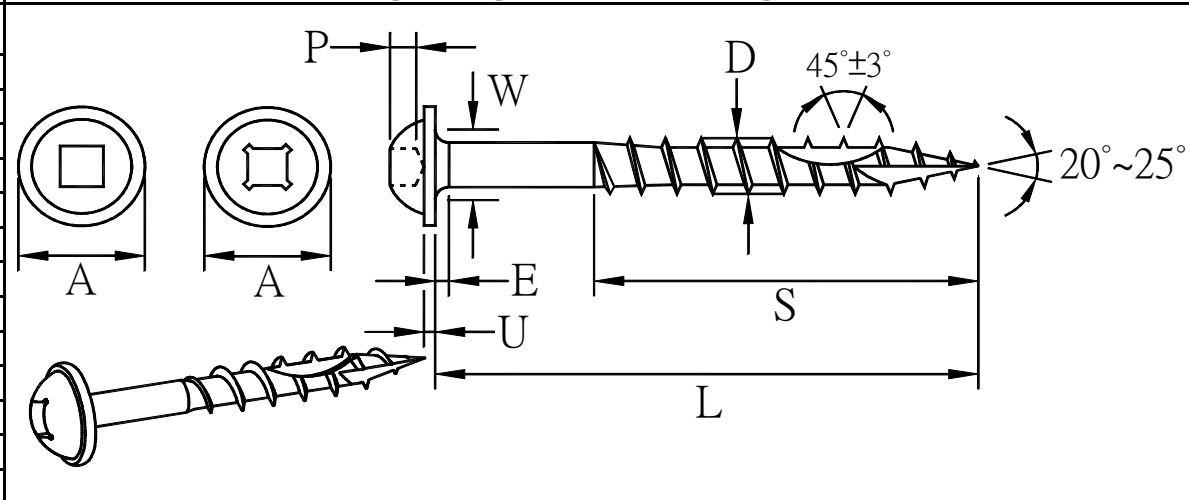

Date	Dim./Spec.	Old	New

Note	Size /Thrds	A	U	Gage				W	E	D	Wire	Torque kgf.cm
				Square		PH-SQ Combo						
				Recess	P	Recess	P					
Normal	#8-9	9.27 8.90	1.14 0.88	#2	1.90 1.66	#2	1.90 1.66	Max. 5.40	Max. 1.20	4.35 4.00	2.95	38
—	#9-9	9.27 8.90	1.14 0.88	#2	1.90 1.66	#2	1.90 1.66	Max. 5.40	Max. 1.20	4.75 4.30	3.20	45
—	#10-9	9.27 8.90	1.14 0.88	#2	1.90 1.66	#2	1.90 1.66	Max. 5.40	Max. 1.20	5.00 4.75	3.47	55
Long size (Over 4")	#10-9	9.27 8.90	1.14 0.88	#2	1.90 1.66	#2	1.90 1.66	Max. 5.40	Max. 1.20	5.50 5.00	3.80	70

**Specifications:**  
**Material:** SAE C1022  
**Recess:**  #2 PH-SQ Combo  
 #2 Square  
**Head:** Round washer head  
**Thread:** 45°CS+Cutter  
**Heat Treatment:**  
**Surface hardness:** HV 320-450  
**Core hardness:** HV 450-800  
**Bending Angle:** > 15°Breaking  
**Thread Length:** Below 1-1/8":full thread  
1-1/4"~1-3/8": 20-22mm  
1-1/2"~3-1/4": Max. 2/3 total length  
**Total Length:** Below 5/8": +0 / - 0.039" (-1.0mm)  
Above 3/4": +0 / - 0.05" (-1.2mm)

Customer approve:  
w/date

Approved by :  
w/date

CAD by : Yu Chen Lin  
w/date 2017.4.17

Issued date :  
w/date 2017.4.17  
year-month-day

**Longer length:**

Length	S (mm)	L (mm)	Wire(mm)
3-1/2"	58~62	86.9~88.9	3.47
4"	58~62	98.6~101.6	3.47
4-1/2"	73~77	111.3~114.3	3.80
5"	73~77	124.0~127.0	3.80
6"	73~77	149.4~152.4	3.80