

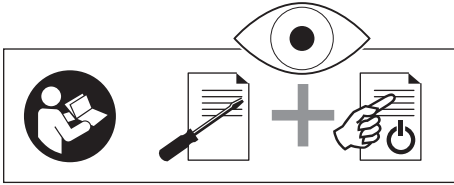

## Free fold E

372.37.XXX



732.23.033

12.0001.010.435.0000.00

**1**

**A** **B**

**C** 2x

372.37.6XX

**3**

**D** **E** **F**

- 372.37.080
- 372.37.085

**2**

**G**

UK: 833.89.000  
 AU: 833.89.001  
 EU: 833.89.002  
 US: 833.89.003

---

**4**

**K** M4 x 8 **H** **I** 372.37.099

**T** **J** 372.91.098

**Q** **L** 4 x 35 **M** **N** **O**

**+**

110° **P**

**+**











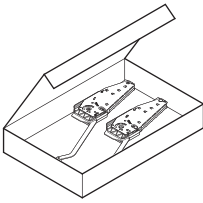
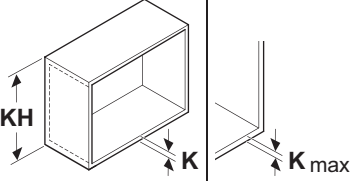
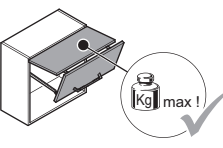
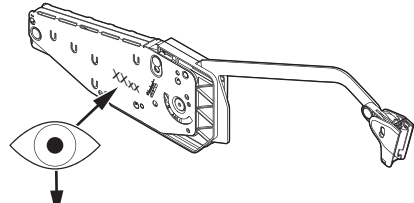

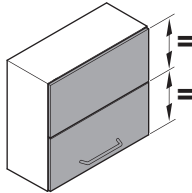
<b>Q</b>		372.64.796	(  )
		372.64.797	(  ) Euro

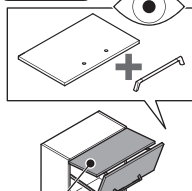
**+**

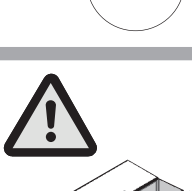
20

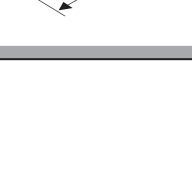
8x **R** 4 x 8

2x **S** 372.37.044

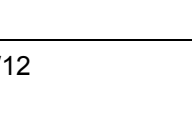
<b>i</b>		<b>mm</b>			
					
 	KH: 450 - 480	16	2,8 - 5,7 kg	<b>B1fo</b>	372.37.600
			5,6 - 11,3 kg	<b>B3fo</b>	372.37.602
			8,3 - 16,3 kg	<b>B4fo</b>	372.37.603
 	KH: 480 - 530	21	2,6 - 5,2 kg	<b>C1fo</b>	372.37.610
			5,2 - 10,6 kg	<b>C3fo</b>	372.37.612
			7,8 - 15,1 kg	<b>C4fo</b>	372.37.613
 	KH: 520 - 590	36	2,4 - 4,9 kg	<b>D1fo</b>	372.37.620
			4,8 - 9,8 kg	<b>D3fo</b>	372.37.622
			7,2 - 14,1 kg	<b>D4fo</b>	372.37.623
			11,8 - 23,3 kg	<b>D5fo</b>	372.37.624
 	KH: 580 - 650	50	2,2 - 4,4 kg	<b>E1fo</b>	372.37.630
			4,3 - 8,8 kg	<b>E3fo</b>	372.37.632
			6,0 - 12,2 kg	<b>E4fo</b>	372.37.633
			10,6 - 20,9 kg	<b>E5fo</b>	372.37.634
 	KH: 650 - 730	59	1,9 - 4,0 kg	<b>F1fo</b>	372.37.640
			3,9 - 7,9 kg	<b>F3fo</b>	372.37.642
			5,8 - 11,6 kg	<b>F4fo</b>	372.37.643
			9,5 - 18,7 kg	<b>F5fo</b>	372.37.644
 	KH: 710 - 790	59	3,5 - 7,2 kg	<b>G3fo</b>	372.37.652
			5,2 - 10,3 kg	<b>G4fo</b>	372.37.653
			8,7 - 17,2 kg	<b>G5fo</b>	372.37.654
 	KH: 770 - 840	69	3,2 - 6,7 kg	<b>H3fo</b>	372.37.662
			4,9 - 9,8 kg	<b>H4fo</b>	372.37.663
			8,0 - 15,5 kg	<b>H5fo</b>	372.37.664
 	KH: 840 - 910	69	4,5 - 9,0 kg	<b>I4fo</b>	372.37.673
			7,3 - 14,6 kg	<b>I5fo</b>	372.37.674
 	KH: 910 - 970	79	4,2 - 8,0 kg	<b>J4fo</b>	372.37.683
			6,80 - 13,5 kg	<b>J5fo</b>	372.37.684
 	KH: 960 - 1010	84	3,9 - 7,6 kg	<b>K4fo</b>	372.37.693
			6,5 - 12,8 kg	<b>K5fo</b>	372.37.694
 	KH: 1000 - 1040	89	3,7 - 7,3 kg	<b>L4fo</b>	372.37.698
			6,2 - 12,3 kg	<b>L5fo</b>	372.37.699

732.23.033

HDE 07/2016

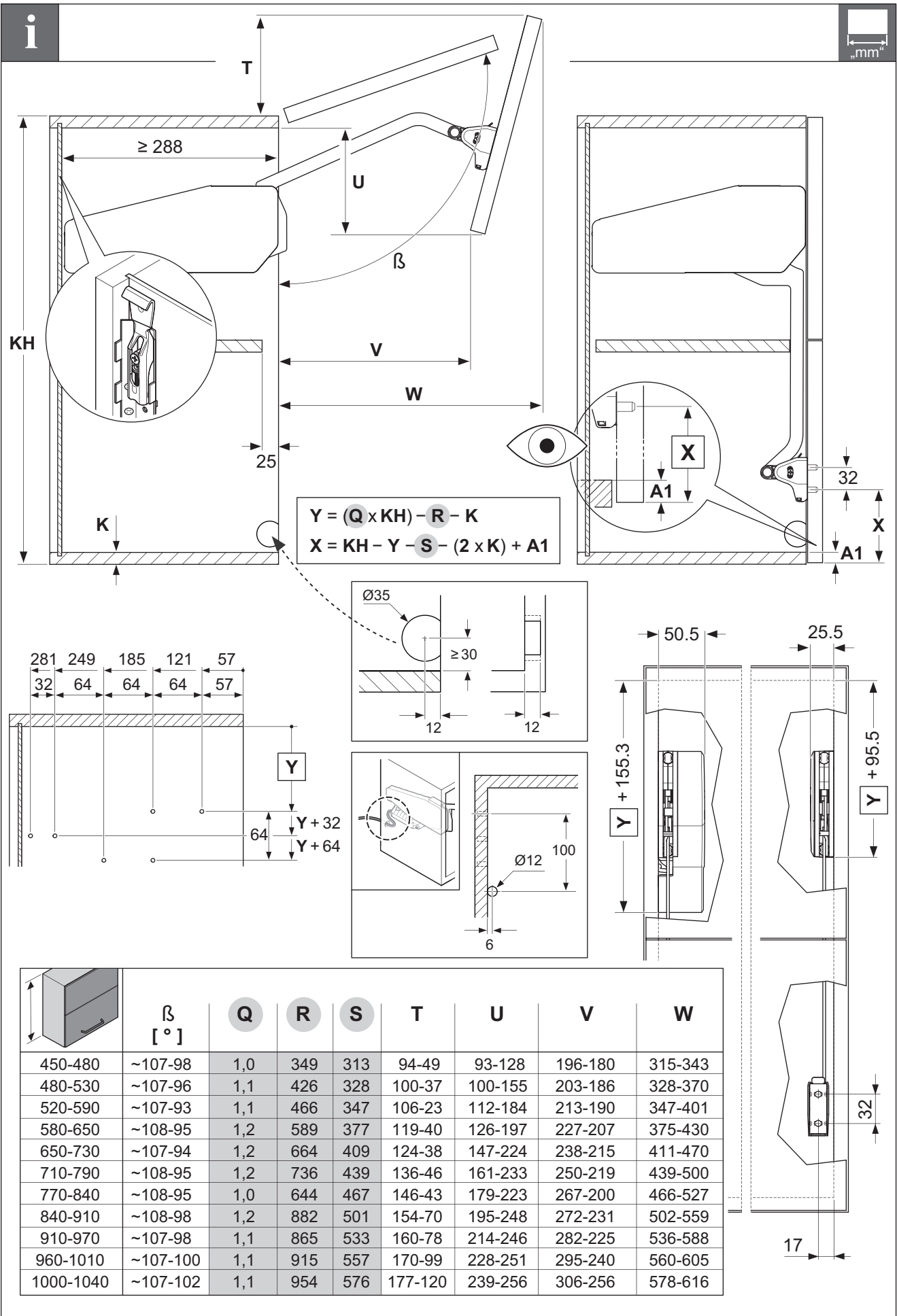

732.23.033

HDE 07/2016

1

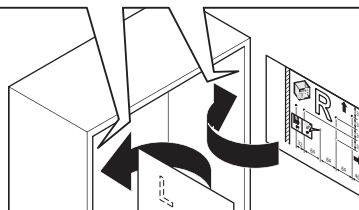
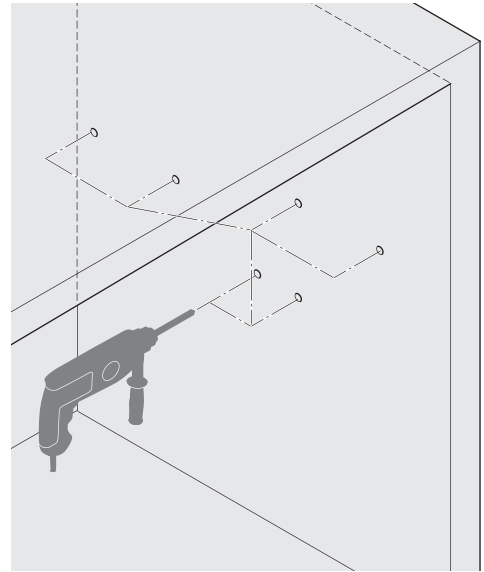
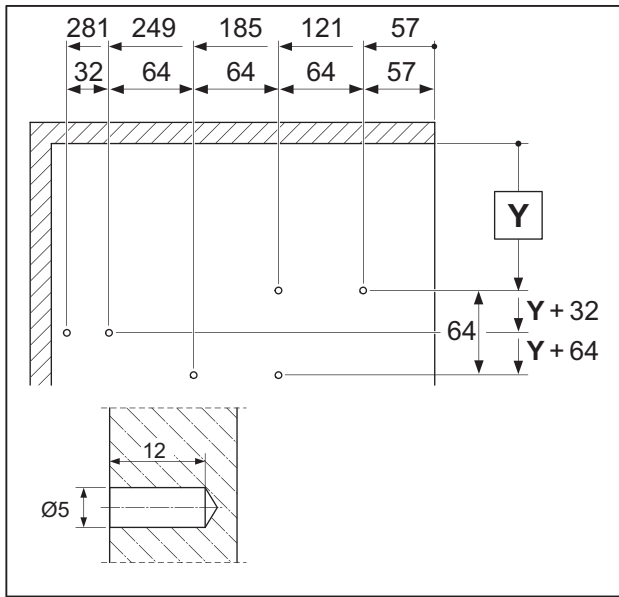

2

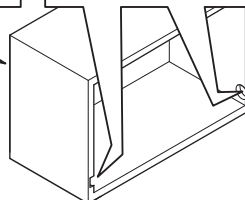
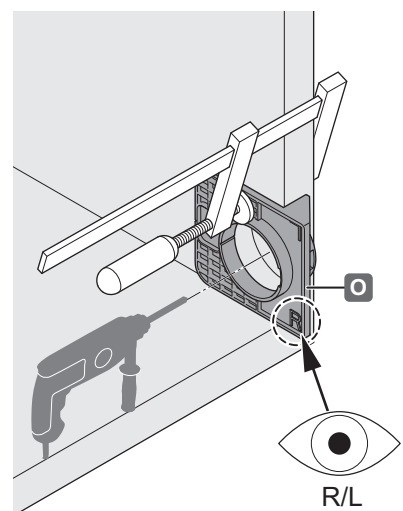
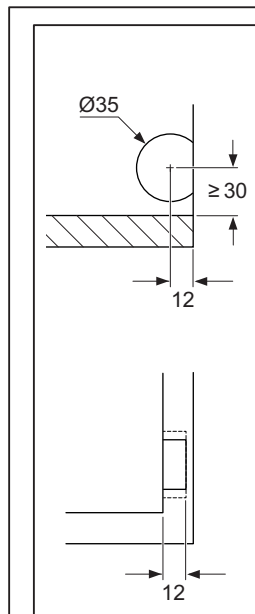
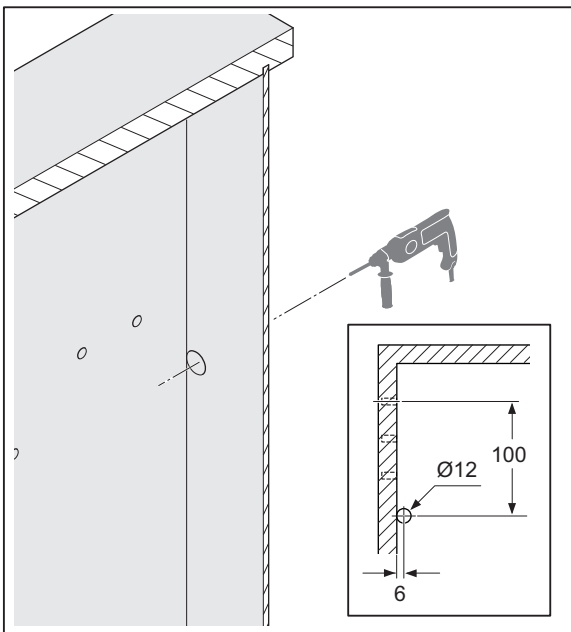
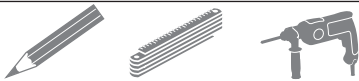

732.23.033

HDE 07/2016

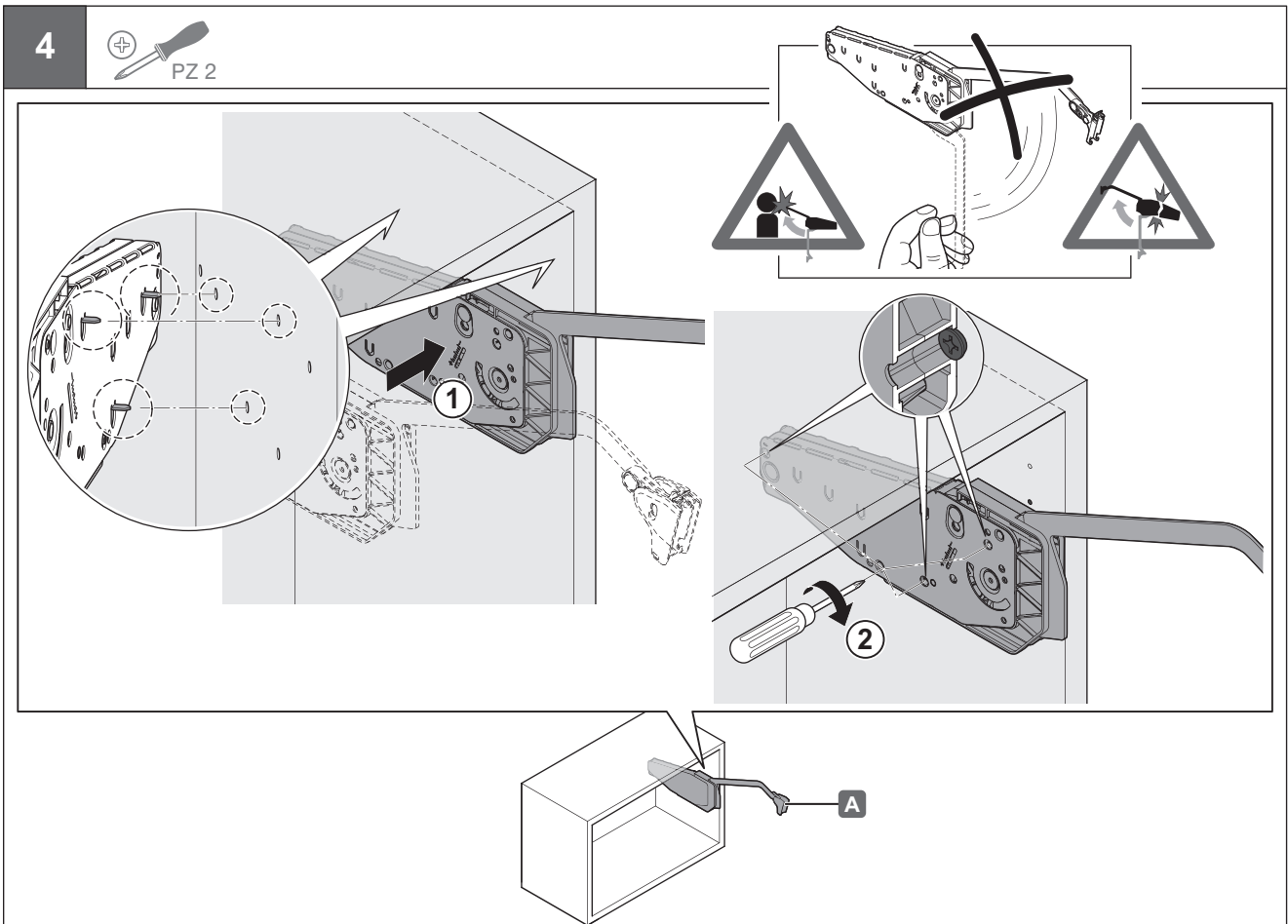
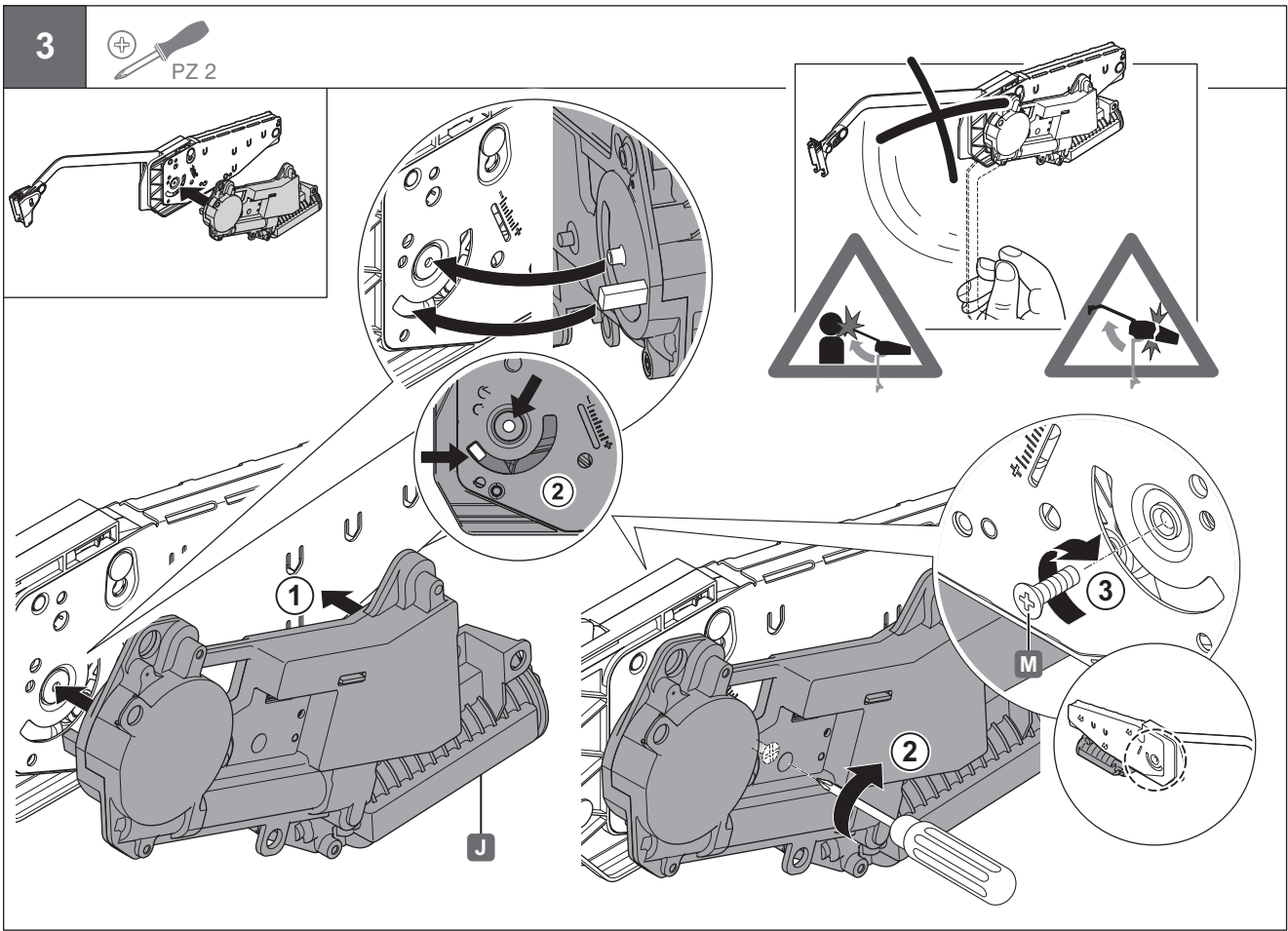

732.23.033

HDE 07/2016

5

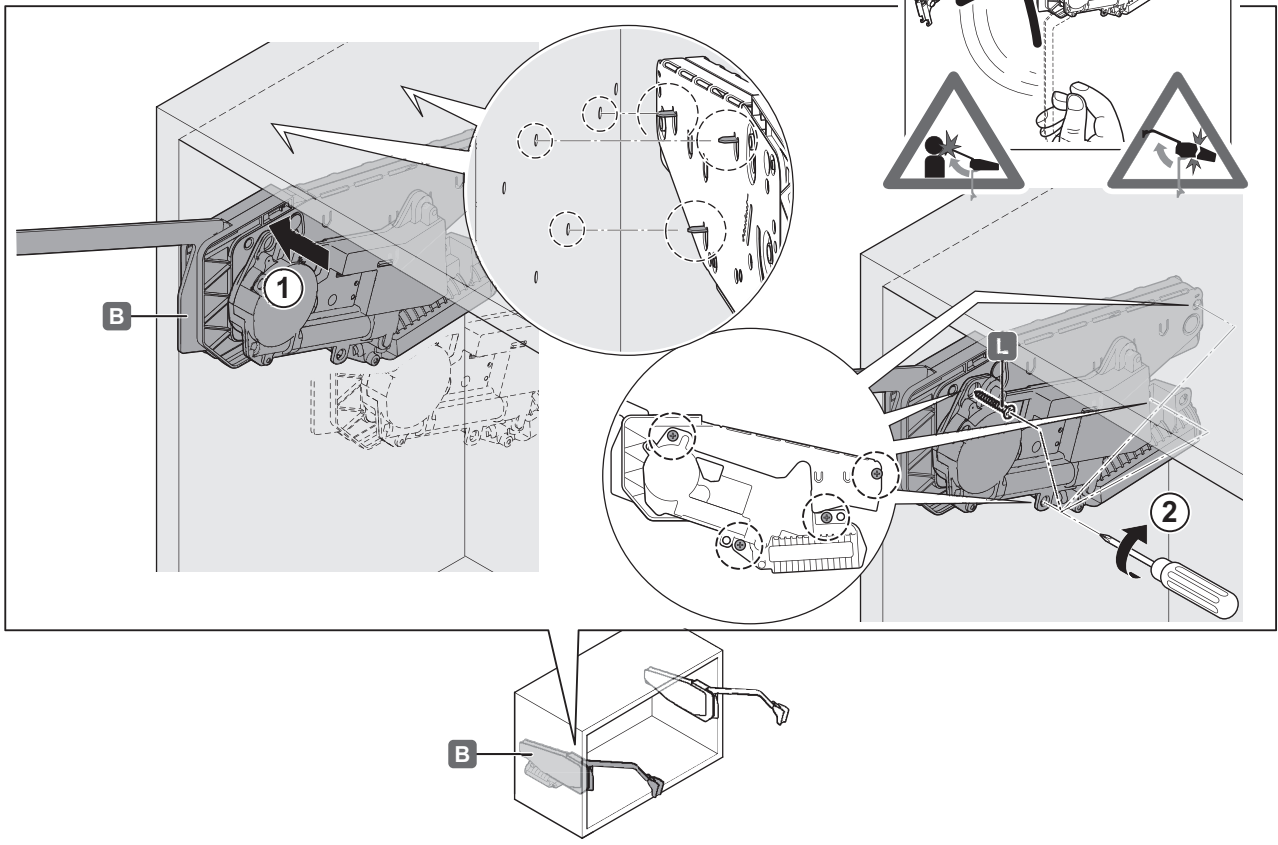

6

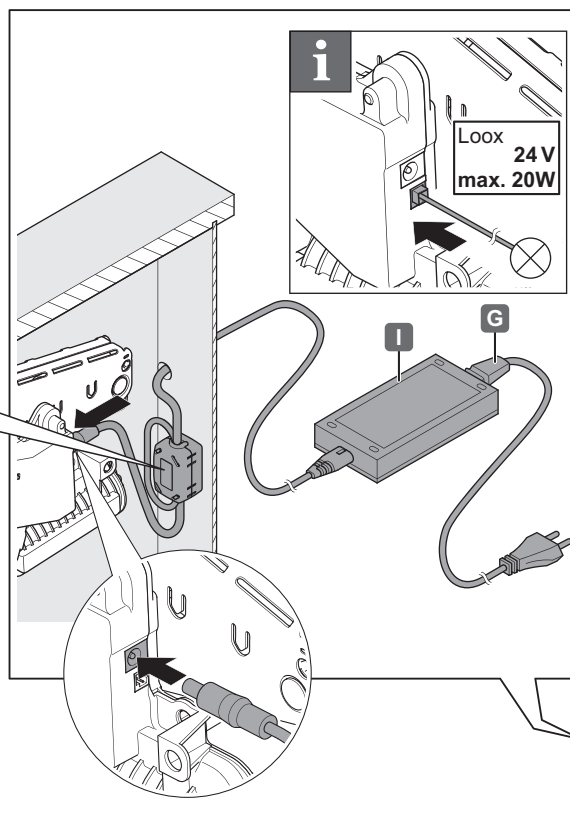
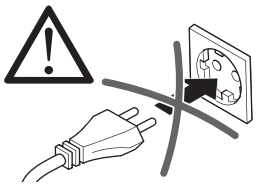

7

CR2032

PZ 2

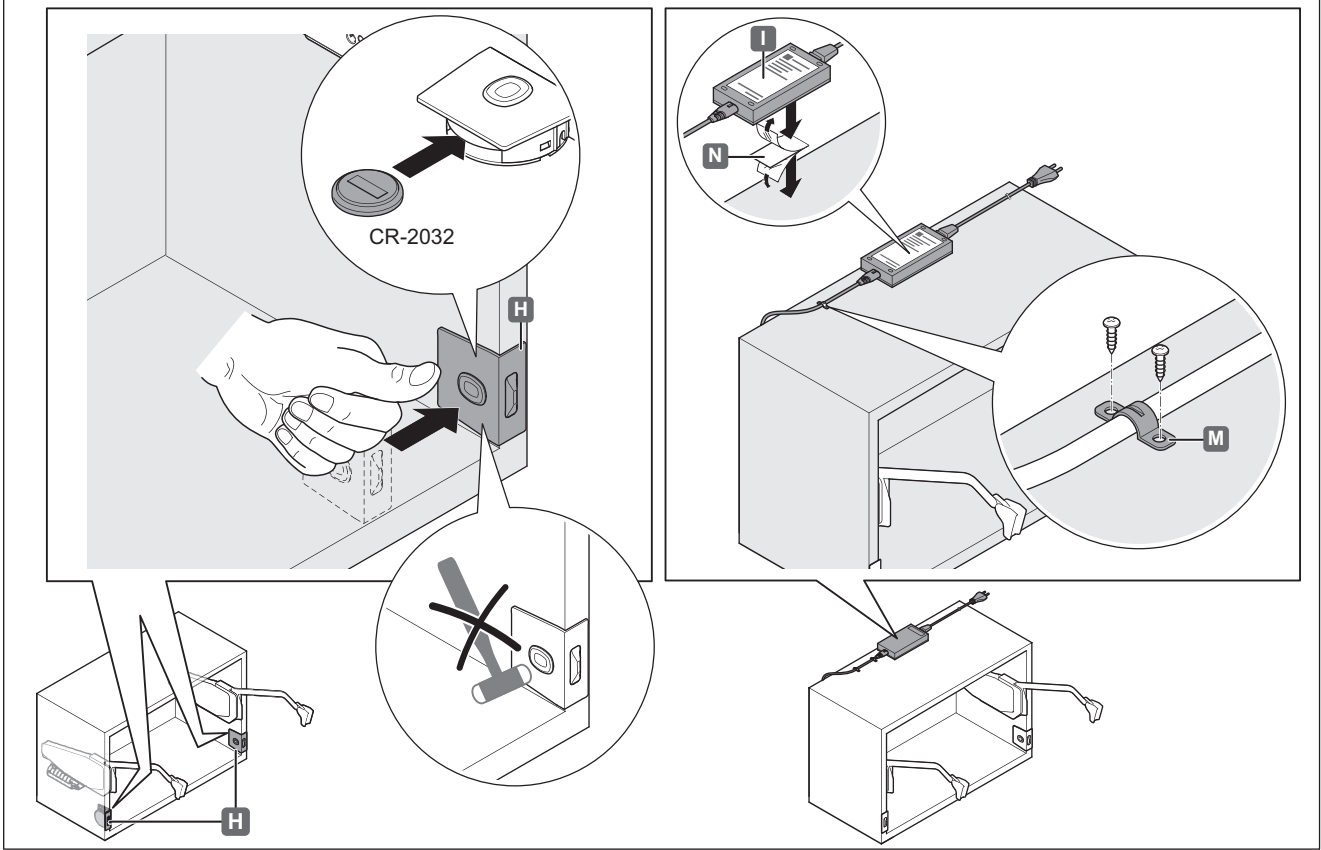

8

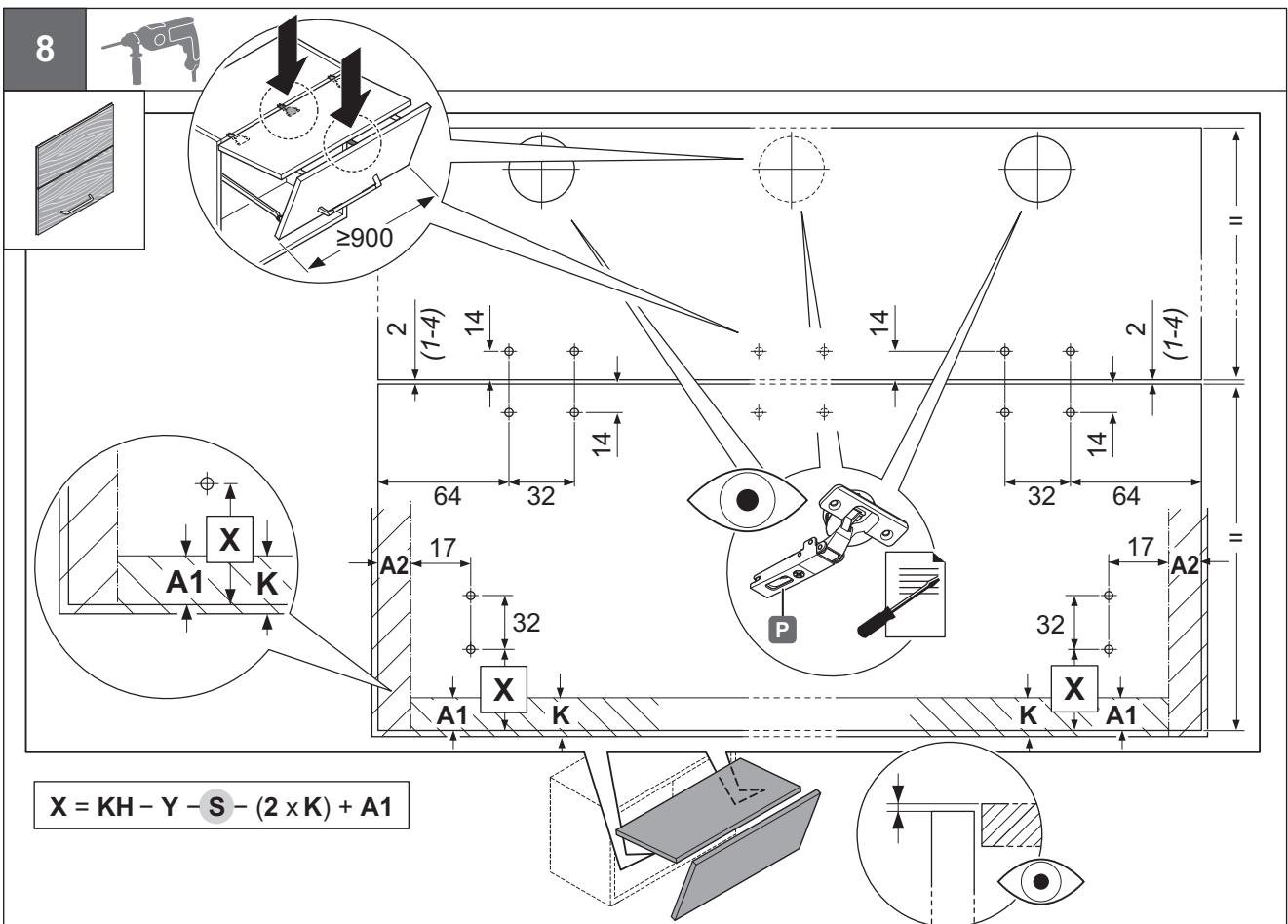

732.23.033

HDE 07/2016

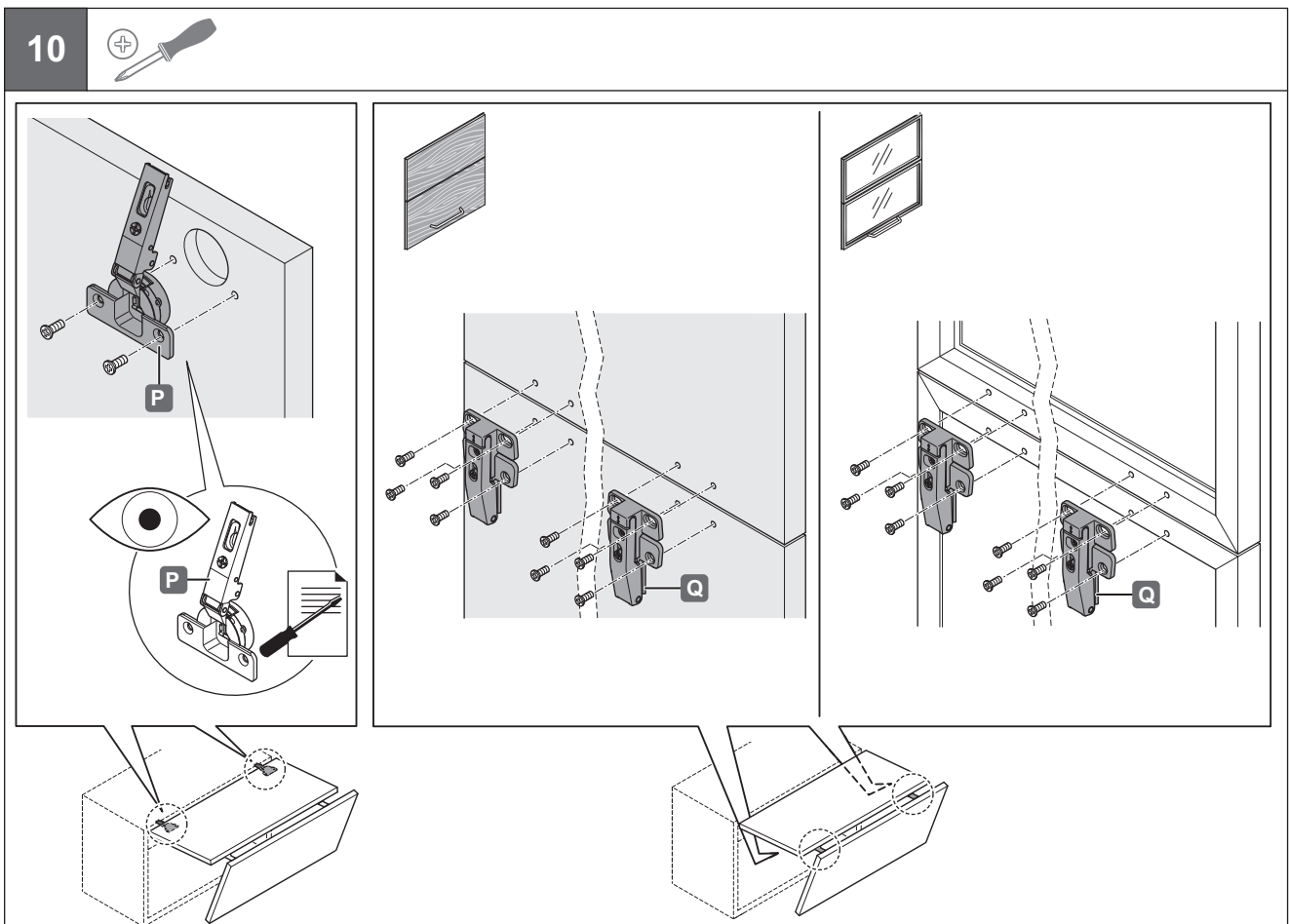
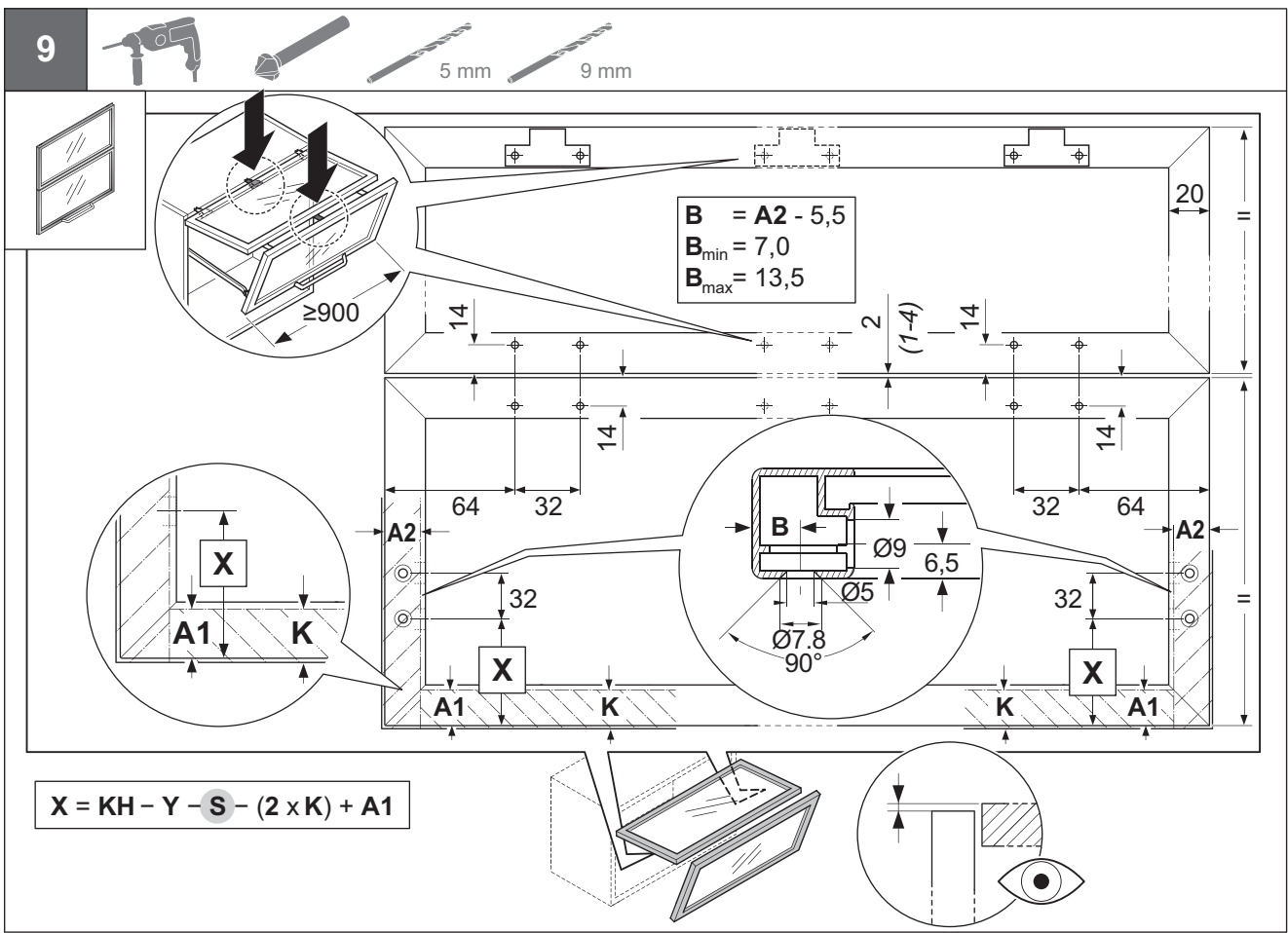



11

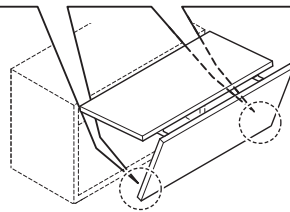
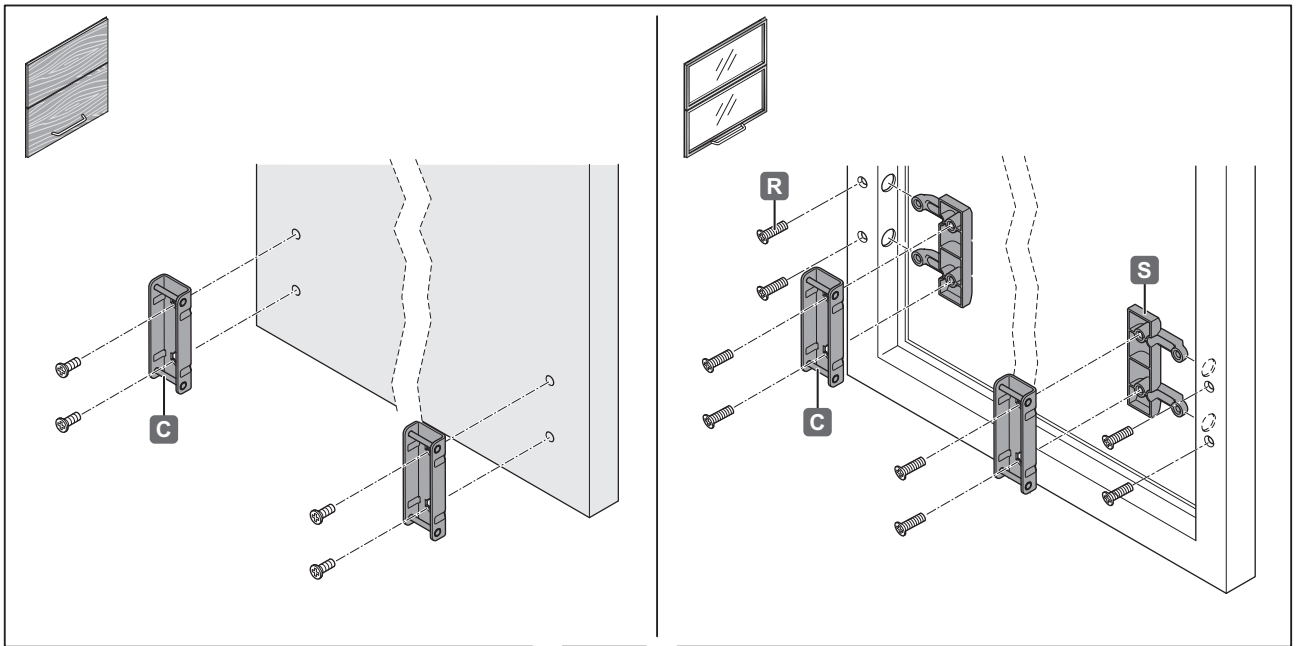

12

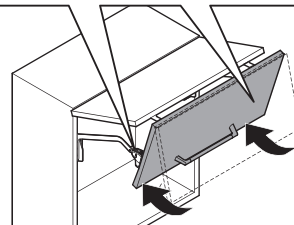
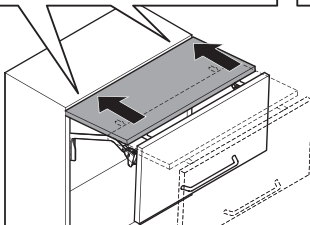
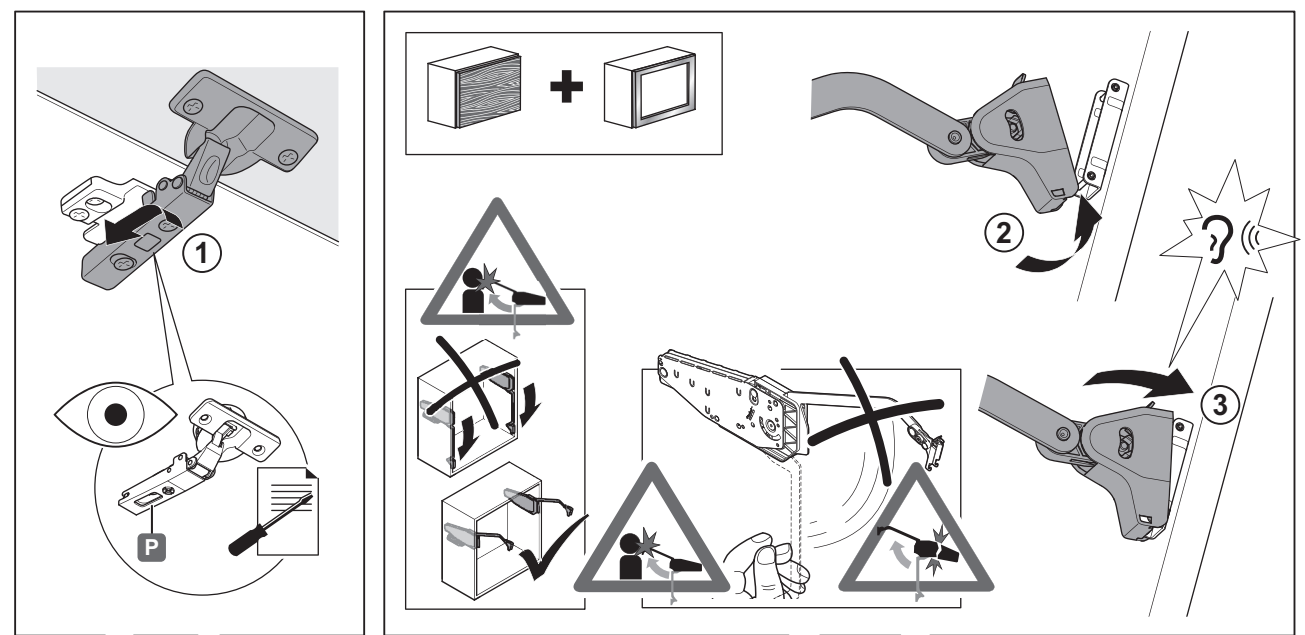

732.23.033

HDE 07/2016

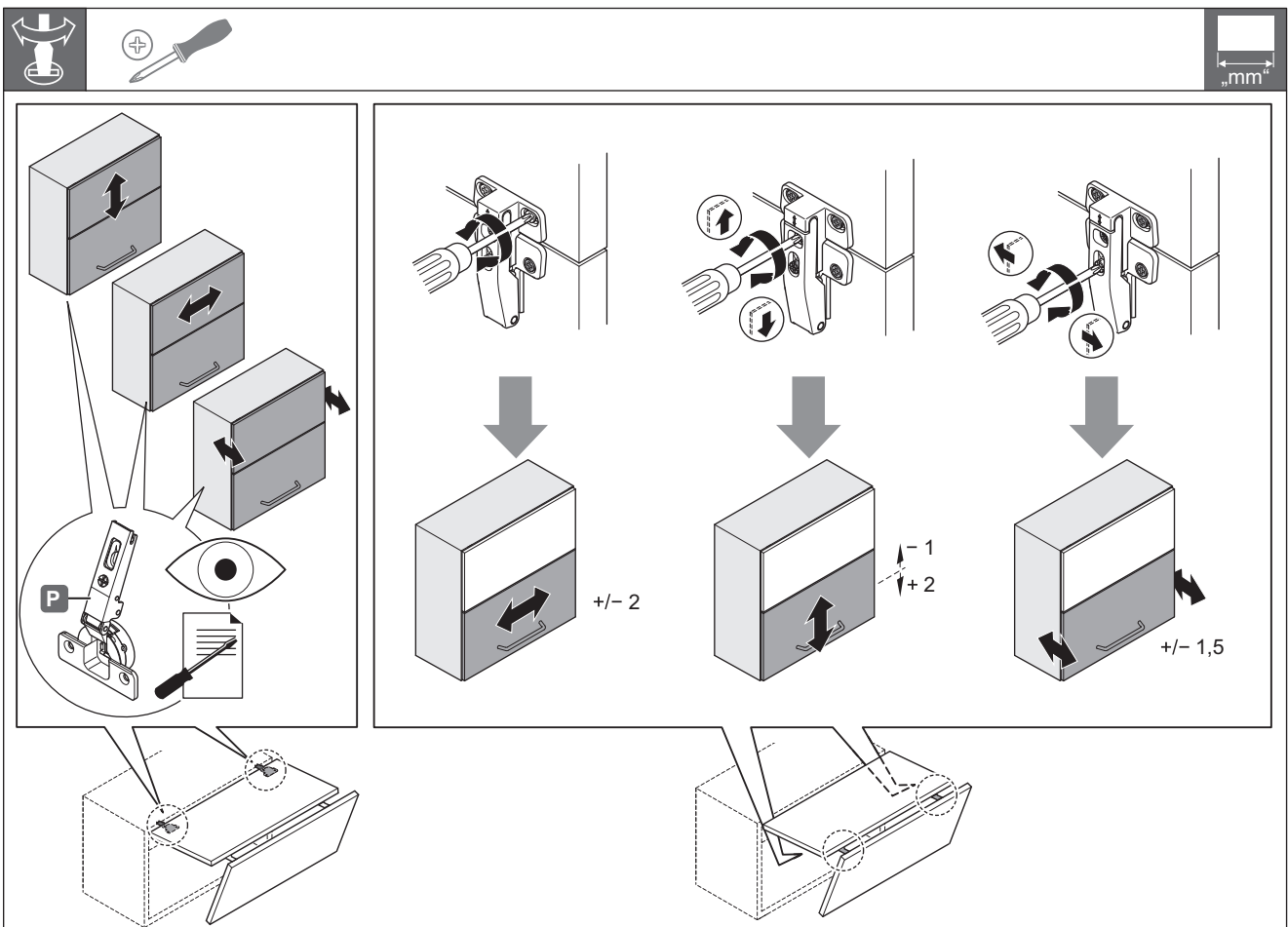
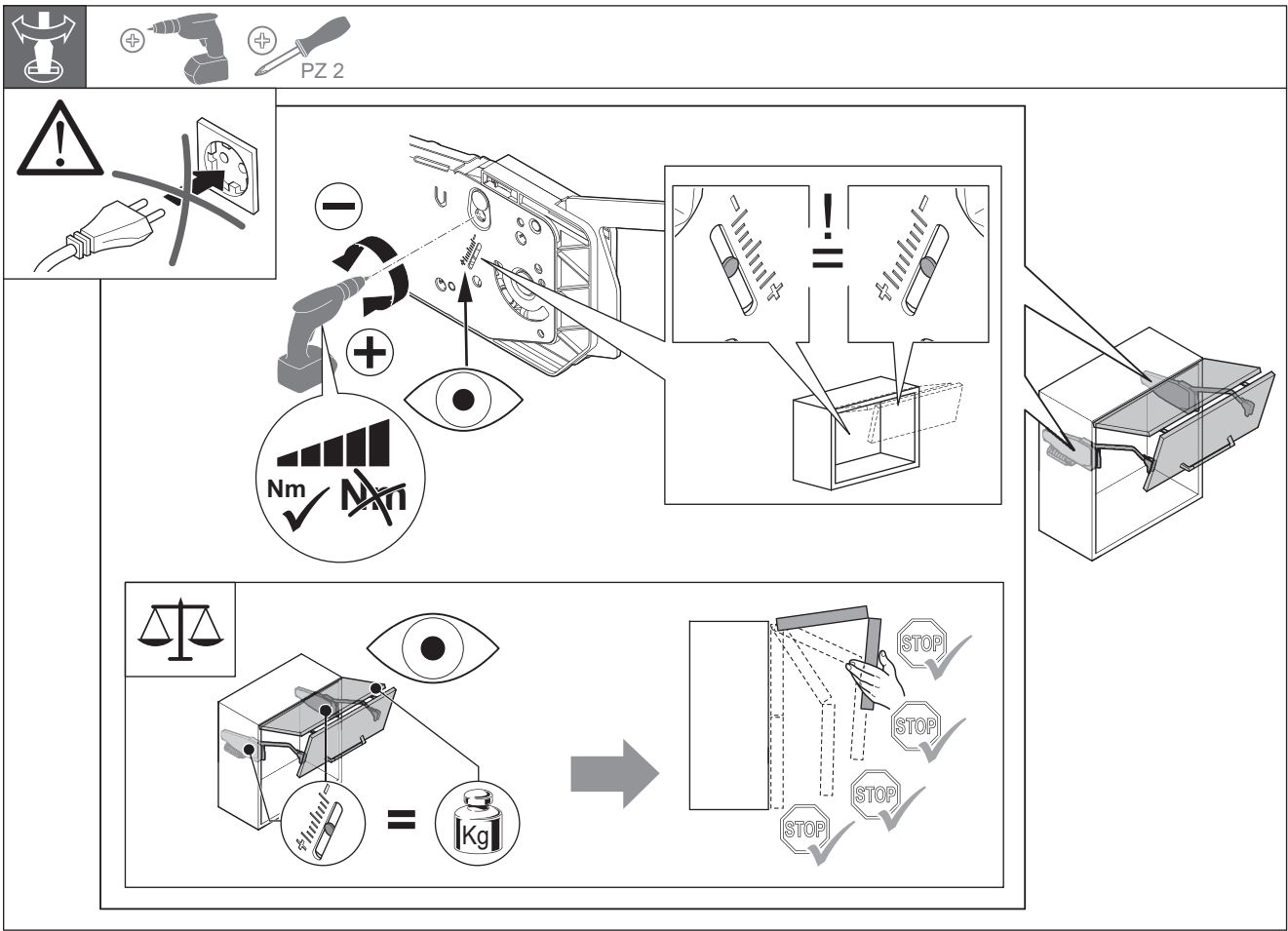



12

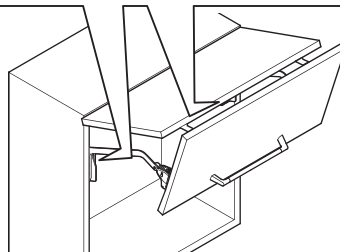
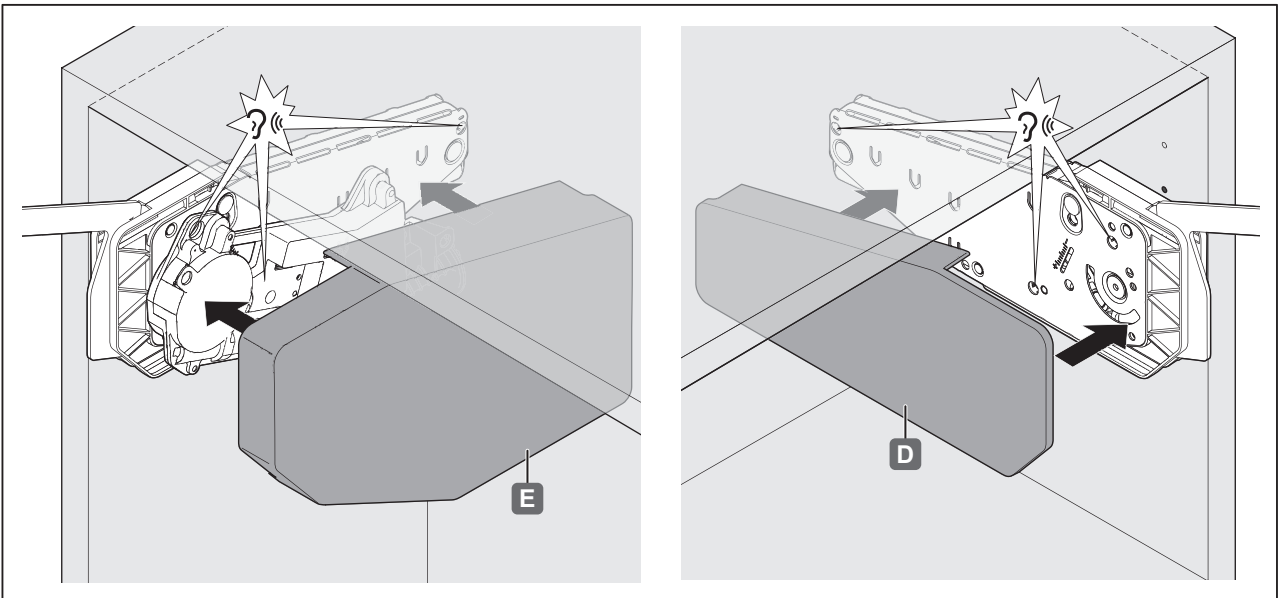

i

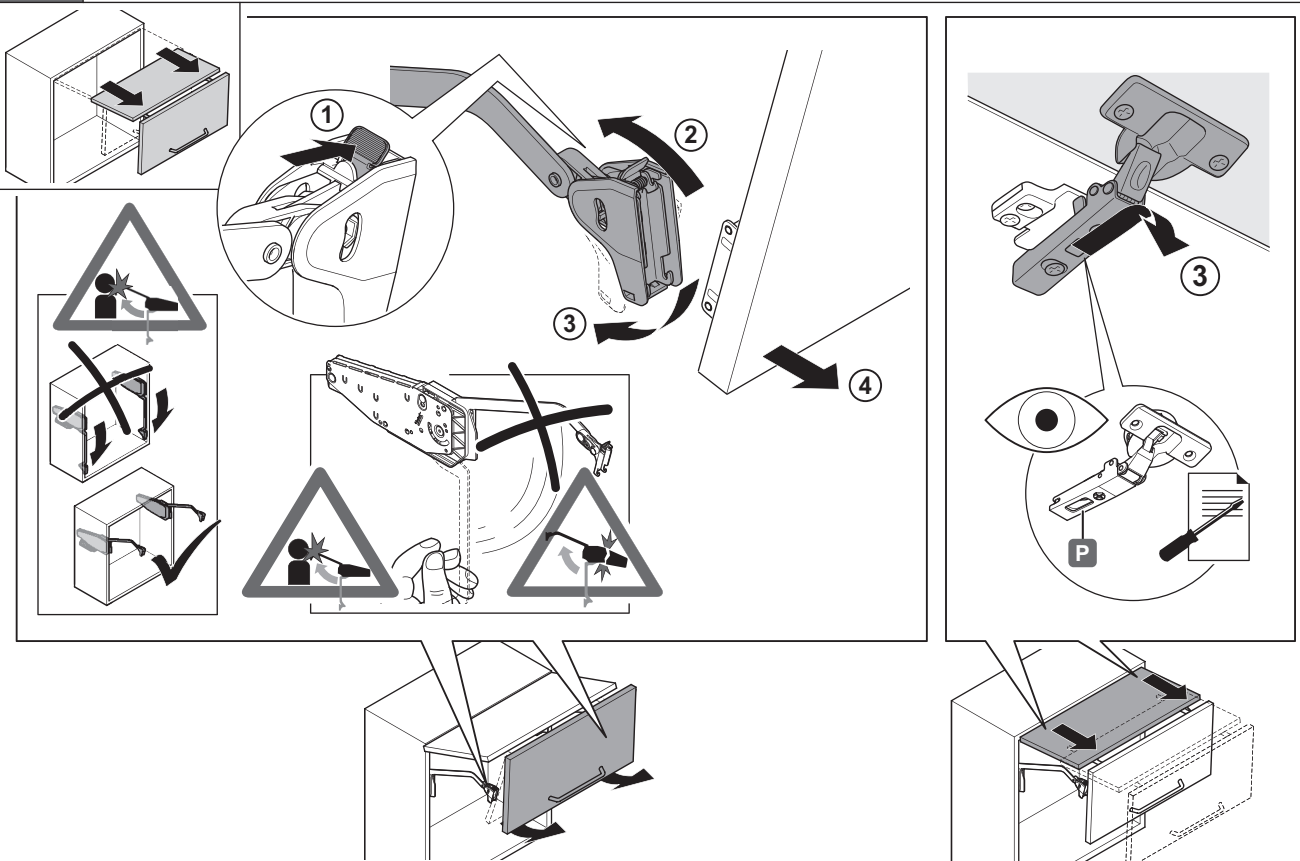

732.23.033

HDE 07/2016